

TELEHANDLER NON-ROTATING TYPE



MT 1440 A



Machine on stabilizers with forks

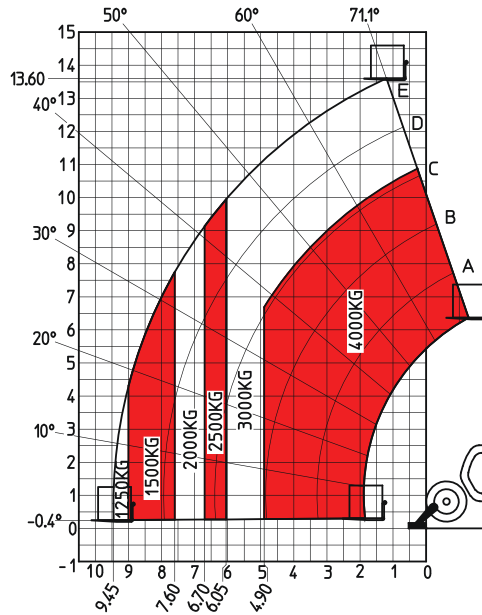

Machine on tyres with forks

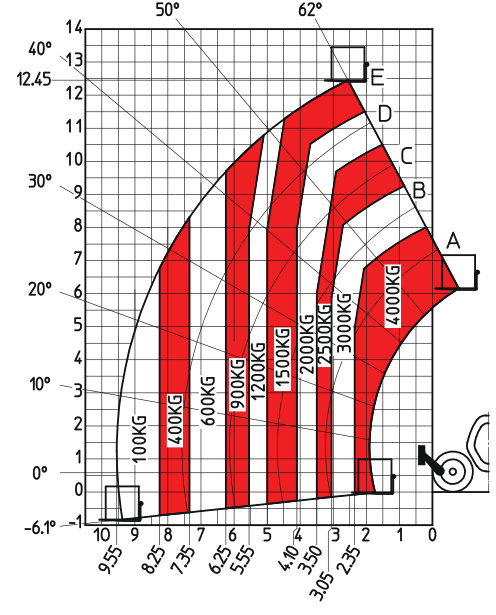

Dimensions

MAKER	MANITOU	(mm)
Model	MT 1440 A	
Max. Lifting Height (m)	13.53	
Max. Outreach (with Forks) (m)	9.38	
Lifting Capacity (on Stabilizers) (kg)	4000	
Turret Rotation (°)	-	
Drawbar Pull (daN)	7850	
Gradeability (°)	14	
Min. Frame Outer Turning Radius (m)	3.99	
GVW (kg)	10940	
Max. Travel Speed (km/h)	25	
Qualifications (when working)	Depends on the attachment	

※ Engine complies with European Stage 4 emission standards.
 ※ The attachments are interchangeable, refer to page 61 for details.

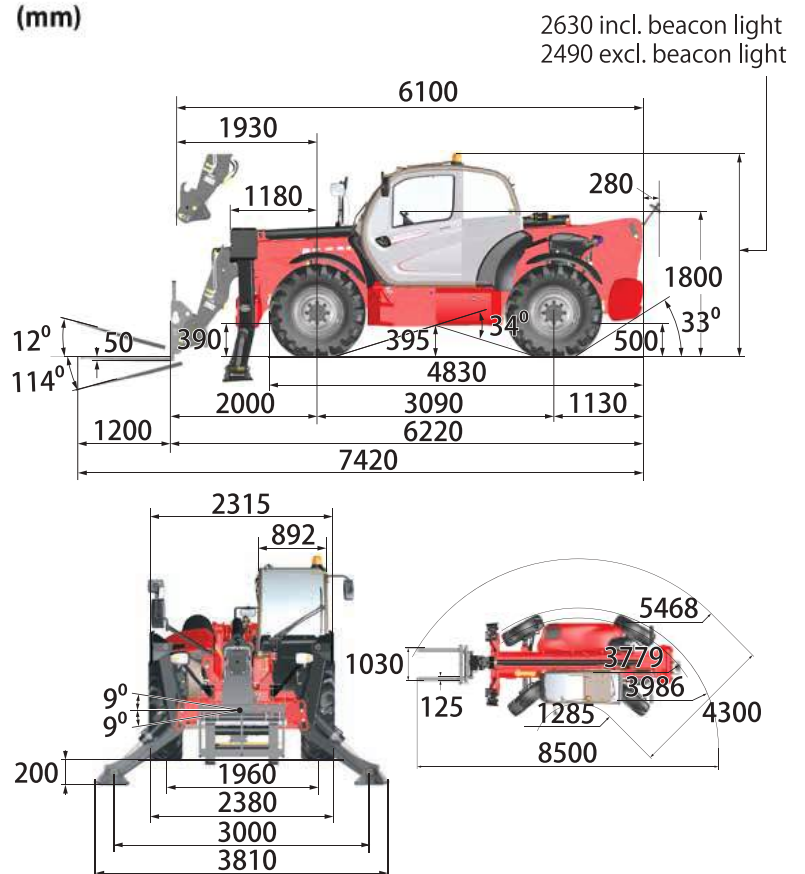

2630 incl. beacon light
2490 excl. beacon light

TELEHANDLER NON-ROTATING TYPE

Machine on stabilizers with PSE 4400 / 365 D platform

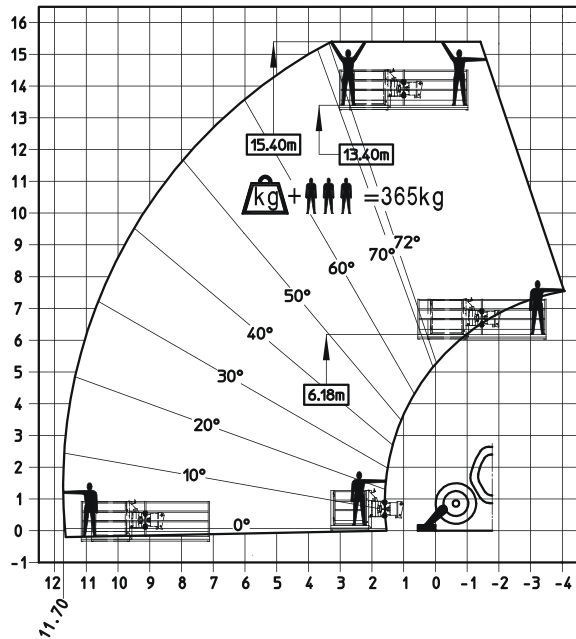

Machine on stabilizers with 2-hook jib P 4000

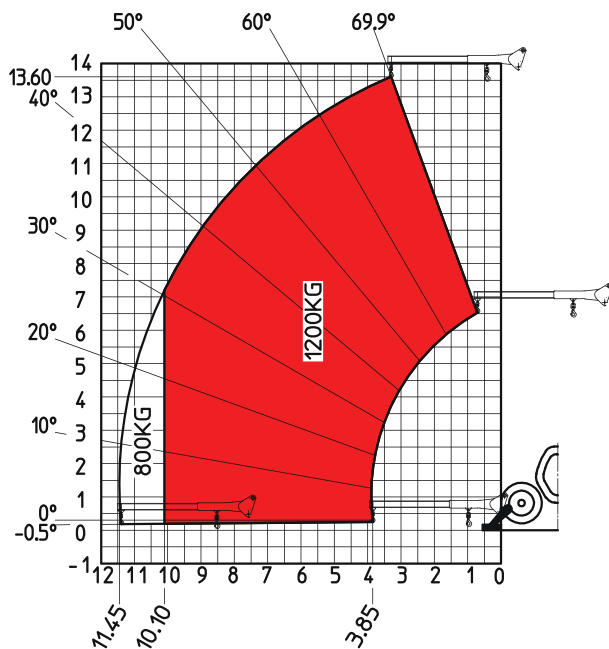

Machine on tyres with 2-hook jib P 4000

